

# CLOSED LOOP PRINTER CONTROL

John Ufford & Rita Mohanty, Speedline Technologies, Franklin, MA

## Abstract

Stencil printing is a critical first step in surface mount assembly. It is often cited that the solder paste printing operation causes about 50%-80% of the defects found in the assembly of PCBs. Printing is widely recognized as a complex process whose optimal performance depends on the adjustment of a substantial number of parameters. It is not uncommon to hear that stencil printing is more of an art than science. In fact, the process is so complex that sub-optimal print parameters usually end up being used. In addition, stencil printing produces relatively noisy data, which makes the print process extremely difficult to control. Minimizing the variance of the deposited location and volumes will improve the quality of the process and produce more reliable solder joints.

In an effort to improve the performance of stencil printers, continuous process monitoring and statistical process control techniques have traditionally been used. However, these techniques require constant process tweaking and highly depend on process expertise. Presently, manufacturing engineers tune control parameters to a recommended nominal value suggested by the equipment and/or solder paste manufacturers. In general, line engineers optimize control parameters by printing a few initial boards and hope that the process stays in control. However, when a process disturbance or drift occurs, the yield of the process typically degrades rapidly to the point of becoming unacceptable.

In general, there are two critical aspects to a printing process. You want to put down the right volume of paste on the right spot. In another word, we not only have to monitor the amount of paste volume we also need to monitor X, Y and  $\theta$  registration of the board. This issue is compounded when dealing with miniature components such as 0201, 01005, 0.4mm and 0.3mm CSP's and lead free paste. Lead-free paste is known to have less spread, or wet-ability, and adds to the challenge.

To improve the performance of the solder paste printing process we have identified several control schemes that can be developed into commercial products with no technical risks. These are automated print registration correction, automated stencil inspection coupled with stencil wiping and finally, advanced closed loop control consisting of print parameters adjustment (such as, squeegee speed) based on the 3D SPI volume, area and/or height measurements.

In this paper we present selected results from the first phase of this work focusing on print registration control, using a closed loop control scheme.

**Key Words:** Closed loop process control, solder paste inspection, print registration, miniature components, process yield, feedback loop.

## Introduction

Closed loop process control can be defined as a system that continually monitors and adjusts a process to maintain a particular target value of an output or outputs. Closed-loop process controls have permeated SMT manufacturing lines, as board assemblers are demanding higher first pass yields at lower cost of ownership. For a closed-loop process control system to function we must identify the output or outputs factors and what input factors influence the variation of those outputs. For example, you may consider paste deposit height, weight, volume, shape, etc. as the outputs for a solder paste printing process and print process parameters, paste type, tooling etc. as the inputs. Once these factors are identified, you must then quantify these factors through the use of formal statistical tools such as Design of Experiments (DOE) to fully realize the benefits.

Presently, closed loop process control is primarily seen in the component placement and reflow processes. One area where process control can be implemented with significant impact to the entire assembly process is the solder paste printing process. Controlling the entire SMT line would be the ultimate goal but this appears to be unrealistic until sometime in the future. As the boards are getting denser and components are getting smaller, most assemblers are looking for ways to prevent defects before they impact yields. We are starting to see genuine interest in a defect

prevention capability rather than defect detection capability. It is well understood that the volume of paste deposit is a direct function of the stencil thickness, even though it is influenced by the process parameters to some extent. Whereas the X, Y and  $\Theta$  or better known as positional accuracy control is a direct function of the printer capability. In order for us to control the print process, we must first control the positional accuracy of the print process.

### Positional Accuracy Control

Positional or registration control can be considered as the most common closed-loop control system applied to a solder paste printer. It deals with accurately placing solder deposits on top of PCB pads. Although most printers have automated systems that perform the alignment of the stencil to the PCB, it is not uncommon to see solder paste deposits end up at locations that are not ideal. Figure 1a, b and c demonstrates such scenarios. It is clear for the figure below, condition 'c', even though delivering correct amount of paste, it will be detrimental to a board assembly process. These print errors can be produced either by board-to-board variations, stencil stretch, inaccuracies in the alignment system or from other sources.

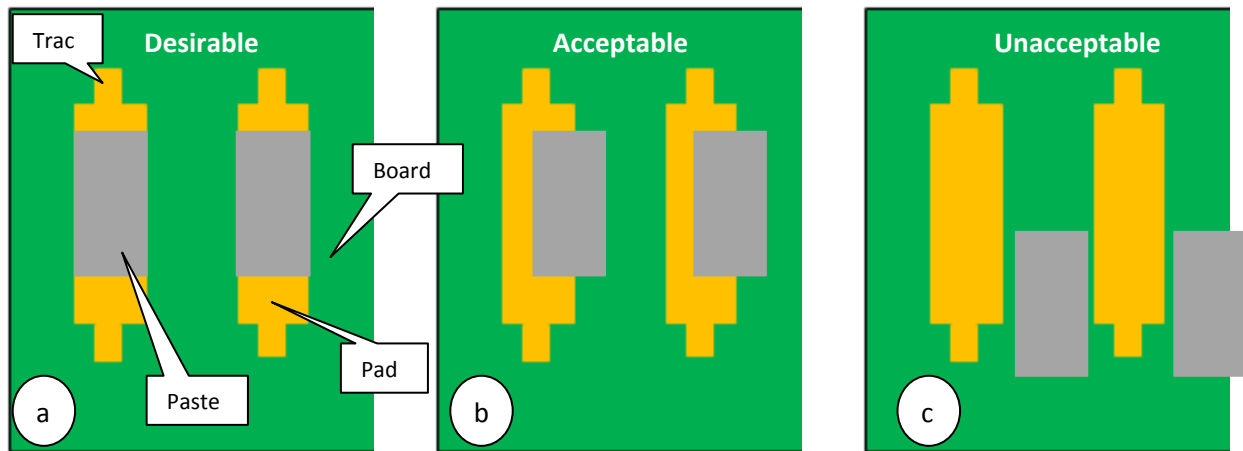

Figure 1. Schematic of paste on pad

### Control Scheme

A closed-loop controller that corrects for deposit positional inaccuracies will typically measure the offset of the printed deposit with respect to the pads on the board and correct the relative position of the stencil to the PCB. All corrections are done in the plane of the stencil or board. In general, the position of the deposits relative to the pads can be measured within the printer. However, this operation can considerably slow down the primary function of the printer, printing, resulting in lower throughput. One way to address this issue is to export the inspection of the board to outside the printer where parallel operation of printing and inspection can take place. Subsequently, the inspection result can be fed back to the printer to make required off-set adjustment to keep the process in control.

To improve the performance of the positional accuracy we are presently testing a closed loop system that uses CyberOptics SE300 SPI system to measure X, Y and  $\Theta$  print off set. This information is then passed on to the printer to and makes appropriate corrections to the print off set as necessary. The closed loop scheme is represented in figures 3 and 4.

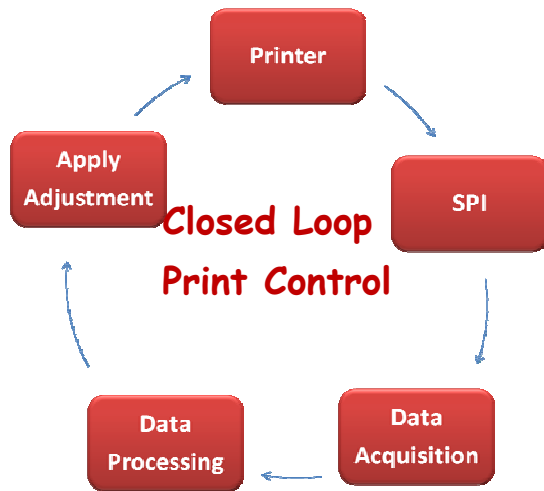

Figure 3. Closed loop control concept

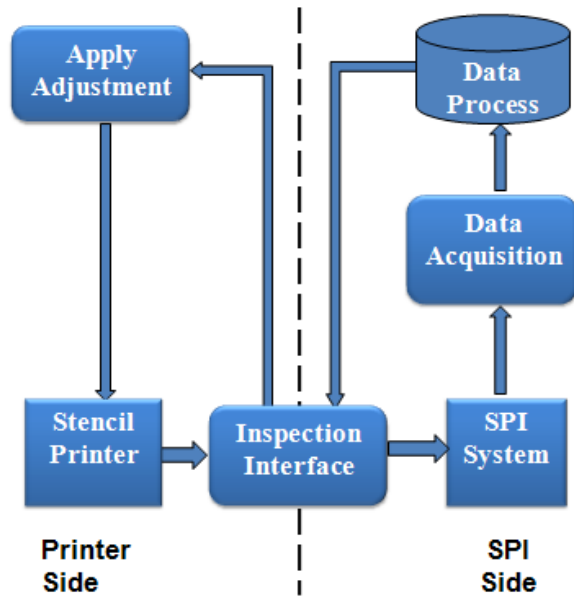

Figure 4. Control scheme

### Experimental

To evaluate the performance of the closed loop control, three tests were conducted.

1. Evaluation tests
2. Baseline test
3. Long run tests

#### *Evaluation tests*

The objective of this test was to evaluate the performance of the closed loop controller interface and acceptable range of correction factor application. Correction factor is defined as the percentage of SPI measured off set value applied to the next board in the printer. The primary function of the controller is defined here as to adjust the print registration for each squeegee direction until it reaches the target value. This test was conducted using standard Speedline test board which is a 254mm x 203mm x 1.575mm, four layer FR-4 board with ENIG surface finish. This is shown in figure 5a. As figure 5a shows the test vehicle is divided into four quadrants with the same pad layout in each quadrant. The top half of the board is a “step and repeat”, while the bottom half is the “mirror image” of the top half. Each quadrants incorporated wide range of commercially available components and packages which is shown in Figure 5b. The print test was run on 40 boards to get statistical confidence in the results.

A gage study on the SPI machine was conducted before the start of the study to ensure the SPI was repeatable. For the gage study one board was inspected 15 times and the result is presented in figure 6. The range for the 15 boards was measured to be less than  $5\mu$  for X-Y off set and  $0.002^\circ$  for  $\Theta$ . This was considered to be acceptable. Based on this results, the X, Y offset specification was set to be  $\pm 0.05\text{mm}$ .

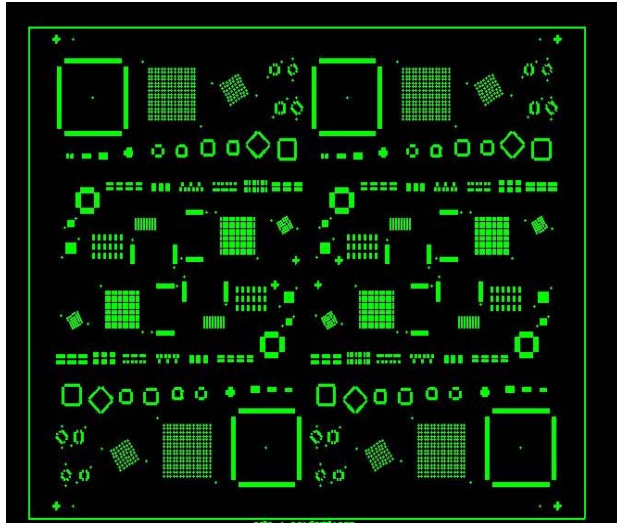

Figure 5a. Test vehicle

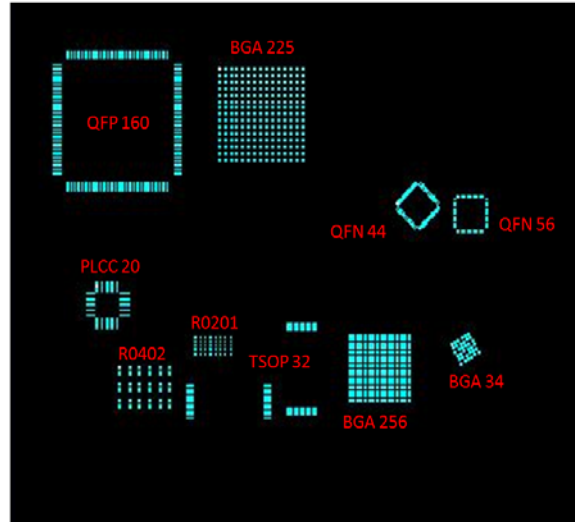

Figure 5b. Inspected components

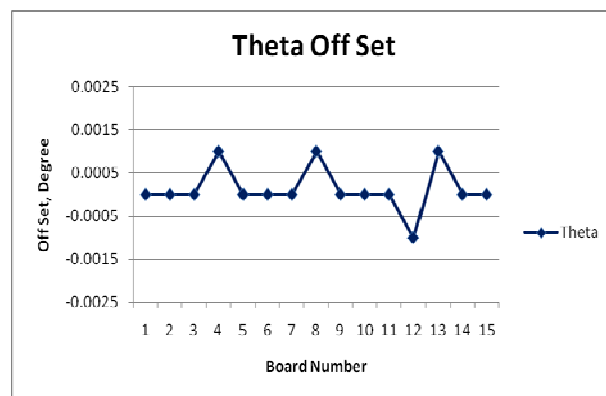
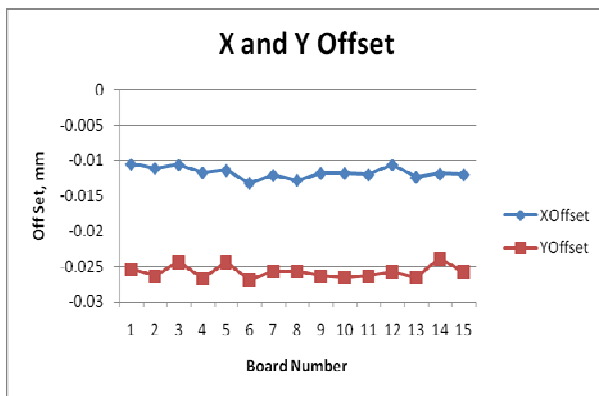

Figure 6. Gage study result for SE300 SPI system

#### Baseline Test

The objective of this test was to baseline the print process without the presence of closed loop control. The test was performed for 100 boards using a commercially available type 4, lead free paste. Board used for this test was a commercial cell phone board, with four phones to a panel. Due to the proprietary nature of the product, the actual image of the board is not shown here. Instead, a representative schematic of the board is shown in figure 9. The board was 191mm X 117mm X 1mm with OSP pad finish. Four areas on the board were chosen to be monitored for X, Y and  $\Theta$  conversance. These four areas are shown on the board by enclosed white box. At the beginning of the test, the board was aligned to the stencil by the operator using visual methods. Once the optimum alignment was achieved, the process was run for 100 boards without any tweaking of the alignment.

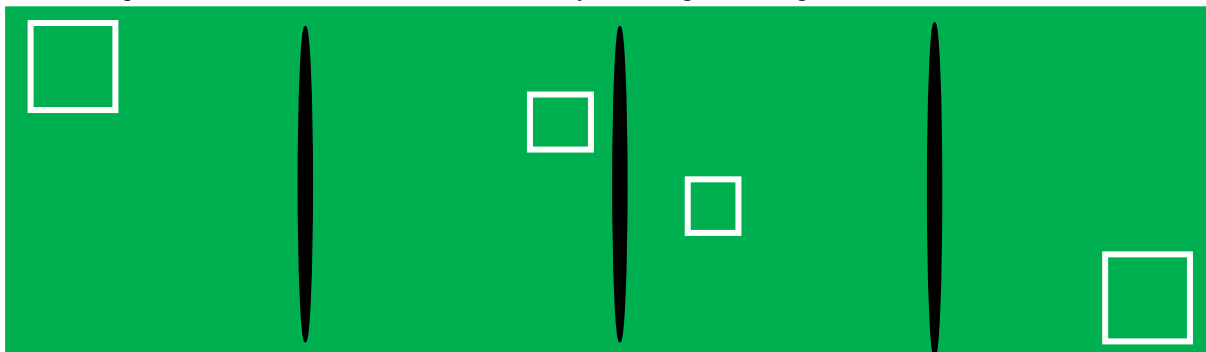

Figure 9. Cell phone board

### Long Run Tests

The objective of this test was to evaluate the stability of the controller for long manufacturing periods (i.e., to simulate a production condition). The test evaluated the ability of the controller to maintain the print process close to the target registration value, and check for rapid convergence. The target for this test was zero offset. The same cell phone board (figure 9) was used for the long run test.

## Results

### Evaluation tests

Figure 7 and 8 shows the results from the evaluation tests. Results from the rear to front direction are shown here with two different correction factors. The graph shows that for 50% correction factor it takes 4 boards to reach the target registration. On the other hand, for 25% correction factor it takes about 8 boards to reach the target registration. As you would predict, smaller correction factor holds the offset value at a much tighter range. Based on these results 50% correction factor was considered to be adequate and was used for the remainder of the tests.

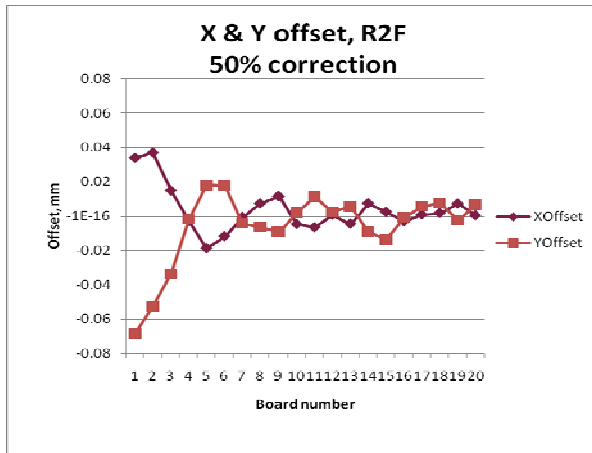

Figure 7a. 50% correction application

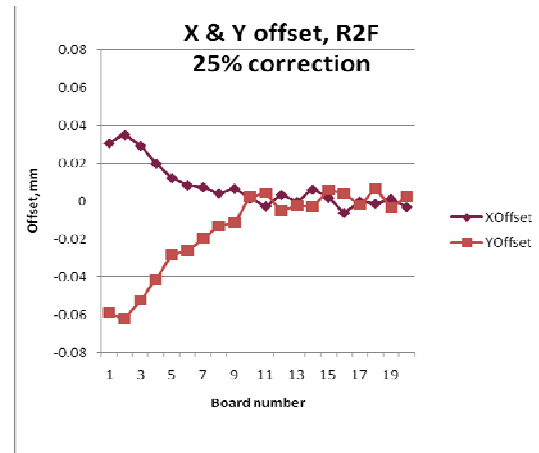

Figure 7b. 25% correction application

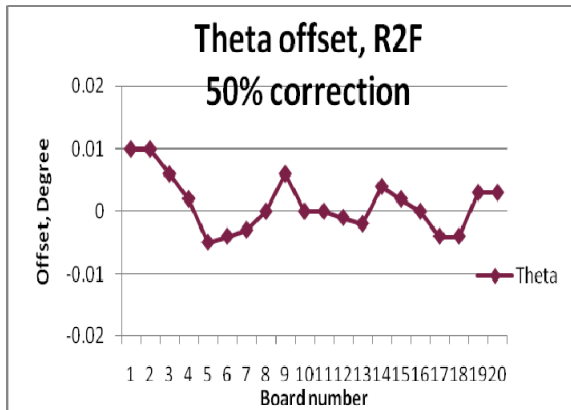

Figure 8a. 50% correction application

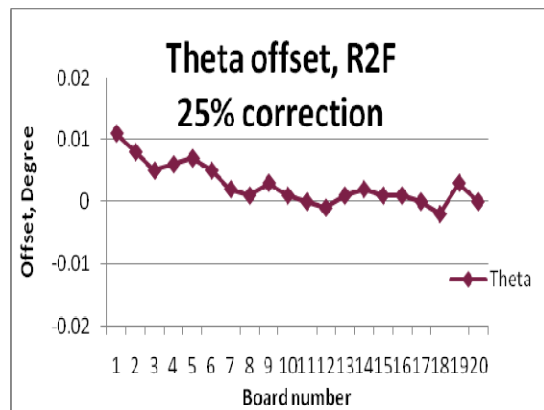

Figure 8b. 20% correction application

### Baseline test

Figures 9 and 10 shows results from the baseline test for F2R stroke direction only. R2F stroke direction showed similar behavior. It is clear from the plots, both X and Y offset fluctuate around a fixed target which is not zero. Additional analysis comparing the baseline results to the long run result will be presented later.

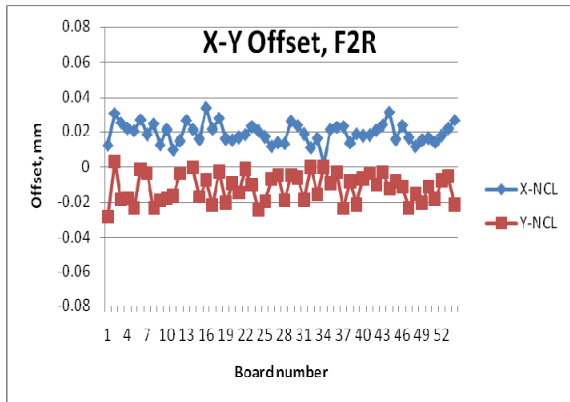

Figure 9. X, Y offset for baseline test

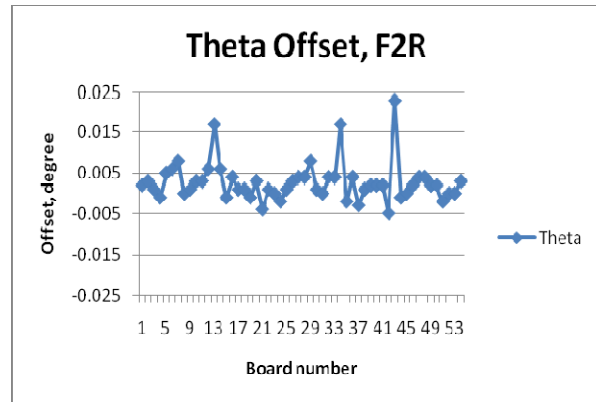

Figure 10. Theta offset for baseline test

*Long rung test*

Results from this study are presented in figures 11-14. We see from these results the closed loop control algorithm is capable of reaching the target value rather quickly. Additionally, it is observed that the average registration value can be maintained close to the target for the entire duration of the test.

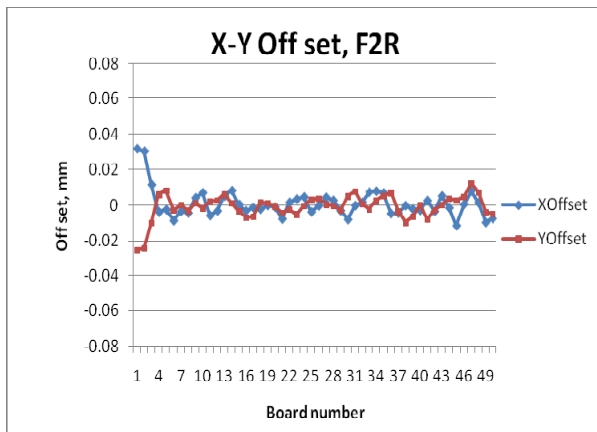

Figure 10. X-Y off set correction for F2R

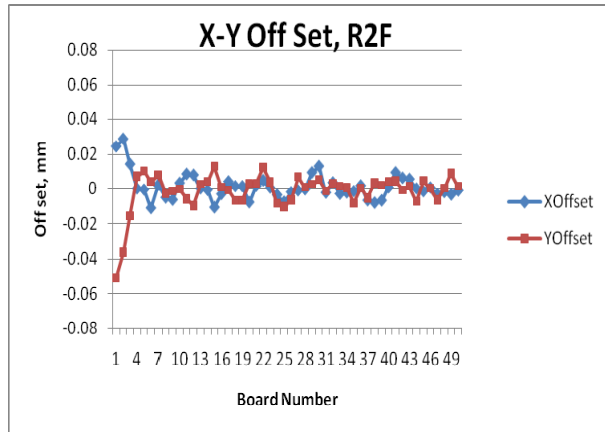

Figure 11. X-Y off set correction for R2F

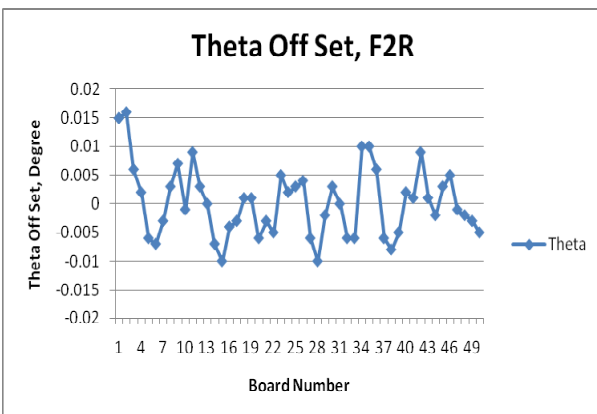

Figure 12. Theta off set correction for F2R

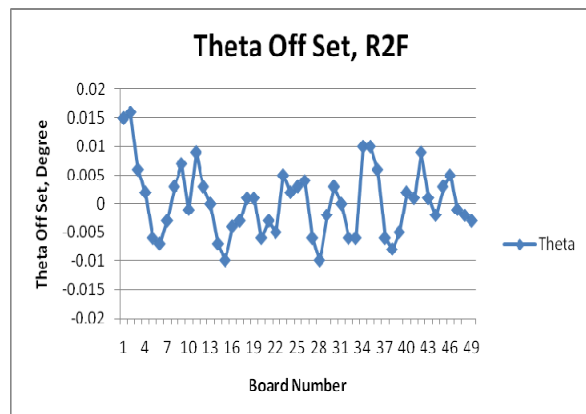

Figure 13. Theta off set correction for R2F

**Discussion**

Print performance comparision between with/without closed loop control gives a measure of process improvements produced by the closed-loop control system. Comparison of the process capability index, Cpk, for X and Y offset measurements for the cell phone board is shown in figure 13. The increase in the Cpk for both X and Y offset with

control is due to the centering and tightening of the print process. Additional statistical analysis confirms the improvement of print performance by employing the closed loop process control. This analysis is presented in figure 14. Figure 14 shows the individual moving chart for Y offset with both with/ without the control. It is clear from this analysis that both mean and control limit improves for process with the closed loop control.

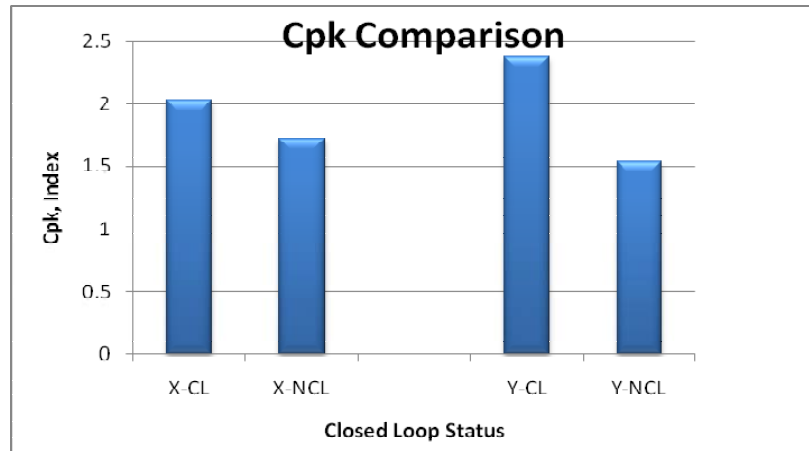

Figure 13. Cpk comparison for with/without closed loop

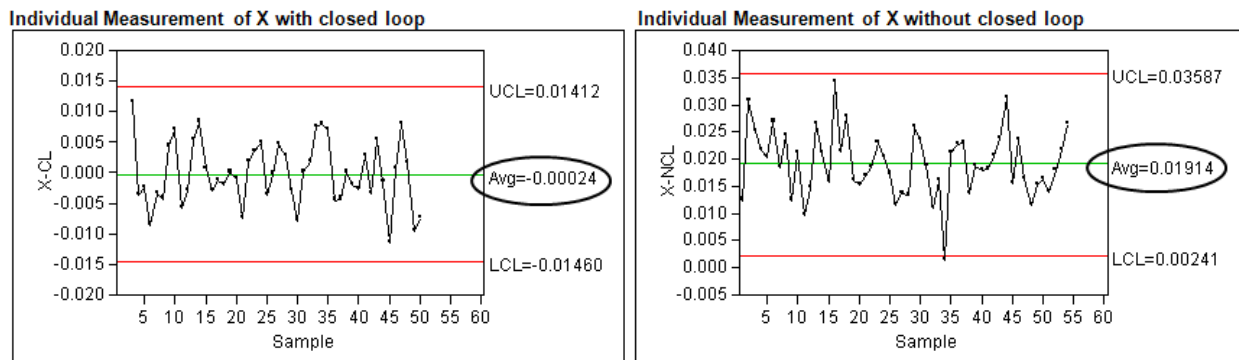

Figure 14. Control chart for X offset with and without control

### Conclusion And Recommendation

Closed-loop controls have been implemented at many stages along circuit board manufacturing lines. They have successfully been implemented within reflow ovens and at the components placement stage. As the push towards product miniaturization becomes inevitable, it is clear that closed loop-process controls for printing process will slowly but surely permeate assembly lines. Closed-loop controllers, when implemented correctly, present the advantages of keeping complex processes within control limits even when small external perturbations affect the product line. In addition, closed loop control minimizes operator intervention and has self-tuning properties.

Limited controlled experiments, in a laboratory environment shows an improvement in the print process capability with the closed loop control in place. The full extent of the benefit can only be accessed by employing such a system in a true high volume production environment.

### Acknowledgement

The authors would like to express their sincerer gratitude to Paul Haugen from CyberOptics for his continued support in operating the SPI system and his insight to inspection system in general. Without his support, this project wouldn't have been successful.